



Adaptatone® Millennium Multiple Tone Signal

30 Watt High Volume, Single Output, RS485 Activation

5530MHV Series

FEATURES

- > 27 tone capability - No additional tone modules needed
- > Output up to 113 dB @ 10 ft
- > PLC compatible
- > Suitable for Division 2 Locations
- > Captive Components
- > RS485 model available

AGENCY APPROVALS

- > NEMA Type 3R
- > IP 44
- > UL 464 and 1604 Listed
- > UL Listed for indoor and outdoor applications in Class I, Division 2, Groups A, B, C & D; Class II, Division 2, Groups F & G; and Class III Hazardous Locations
- > cUL C22.2 No. 205 (24AQ, 24N5 & 24Y6 models)
- > TUV Rheinland Certified
- > CE Marked, LV & EMC Directives, (24Y6 AC only & 24AQ models)

SPECIFICATIONS

- > Speaker can be rotated and locked in any horizontal direction
- > 24V DC battery backup terminals provided

The Edwards 5530MHV Adaptatone Millennium is a heavy-duty, high volume, 30 watt, industrial signaling device capable of producing volume-controlled, high-decibel tones. It uses a microprocessor circuit to create 27 distinctive tones. A single tone may be selected by setting a miniature switch within the unit. For a complete listing of all 27 tones, see page 4-55.

The Adaptatone Millennium can be activated from field-wired, normally open contacts, or a 24VDC or 120VAC external voltage source such as an output of a PLC. Normally open contacts can be obtained from the 5538-4 and/or 5538-4R Adaptatone Signal Actuators. See page 4-49.

The 5530MHV-485Y6 is designed to be connected to RS485 networks, allowing full serial signaling communication control.

Designed for industrial applications. Typical applications include emergency warning systems, plant evacuation and security intrusion alarms, process monitoring, shift start-and-dismissal horns, and paging signals.

The 5530MHV is designed for either 1/2" (13mm) conduit or surface mounting. See Adaptatone Signaling Installation, pages 4-56.

D-04



TECHNICAL INFORMATION

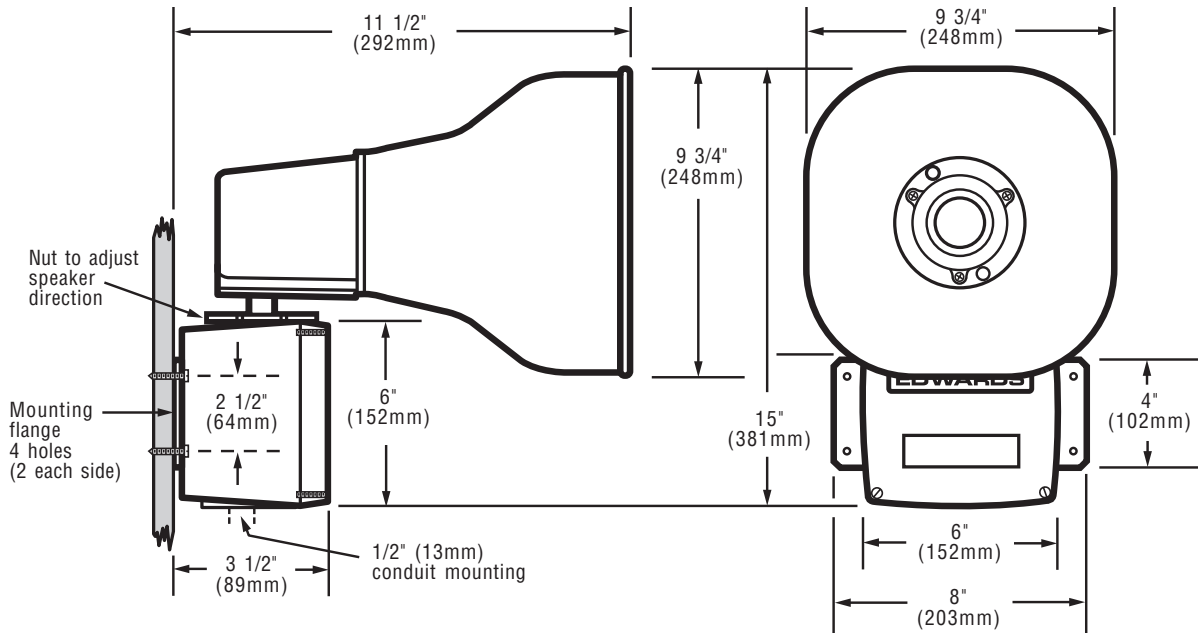

Cat. No.	Operating Voltage	Input Card Activation Voltage	Signal Off Standby Current (Amps)	Signal On Operating Current (Amps)
5530MHV-24AQ	24V DC	24VDC	0.10	1.22
	24V AC 50/60 Hz		0.10	2.21
5530MHV-24Y6	120V AC 50/60 Hz	24VDC	0.10	0.63
5530MHV-120Y6	240V AC 50/60 Hz	120VAC	0.07	0.30
	125V DC		0.04	0.37
	250V DC		0.02	0.17
5530MHV-485Y6	120V AC 50/60 Hz	RS485	0.10	0.63
	240V AC 50/60 Hz		0.07	0.30
	125V DC		0.04	0.37
	250V DC		0.02	0.17

SIGNAL INPUT LOAD CHARACTERISTICS* (PLC output to meet following product input parameters)

Cat. No.	Operating voltage	Max. off state leakage current (mA)	Continuous on current (mA)	Surge (inrush/duration) Amps/milliseconds
5530MHV-24AQ	24V DC only	2	740	8/4
24VDC Input Board	5V DC to 24V DC	2	6	—
120VAC Input Board	120VAC 50/60 Hz	5	13	—

*This device is PLC compatible and may be operated by PLCs with output characteristics that match the input load requirements of this signal.